

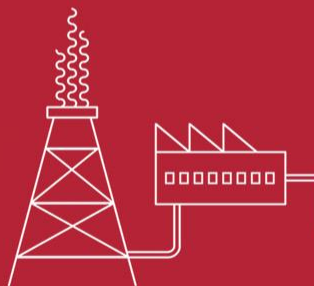

Prelegent: Krzysztof Czernski
Seatech Engineering
BUNKIERKI LNG – specyfika jednostek



[Warszawa - 28 listopada 2019 r.]

Polska Platforma LNG 2019



[Warsaw - 28 November 2019]

Polish LNG Conference 2019

Patronat Honorowy | Honorary Patronage



Organizator
Organizer



Współorganizator
Co-organizer



Partner Generalny
General Partner



Partnerzy | Partners



Partnerzy Medialni | Media Partners



Tłumaczenie zapewnia
Bireta

The translation is
provided by Bireta





CONTENT:

1. Gas as fuel– market overview
2. LNG– Bunkering methods
3. LNG BV– Cargo Containment System
4. LNG BV– Cargo handling equipment
5. LNG BV– maneuvering
6. LNGBV– existing fleet

Patronat Honorowy | Honorary Patronage



Organizator
Organizer



Współorganizator
Co-organizer



Partner Generalny
General Partner



Partnerzy | Partners



Partnerzy Medialni | Media Partners



Tłumaczenie zapewnia
Bireta

The translation is
provided by Bireta





GAS AS FUEL – MARKET OVERVIEW

Patronat Honorowy | Honorary Patronage



Organizator
Organizer



Współorganizator
Co-organizer



Partner Generalny
General Partner



Partnerzy | Partners



Partnerzy Medialni | Media Partners



Tłumaczenie zapewnia
Bireta

The translation is
provided by Bireta





NATURAL GAS AS MARINE FUEL OF THE FUTURE

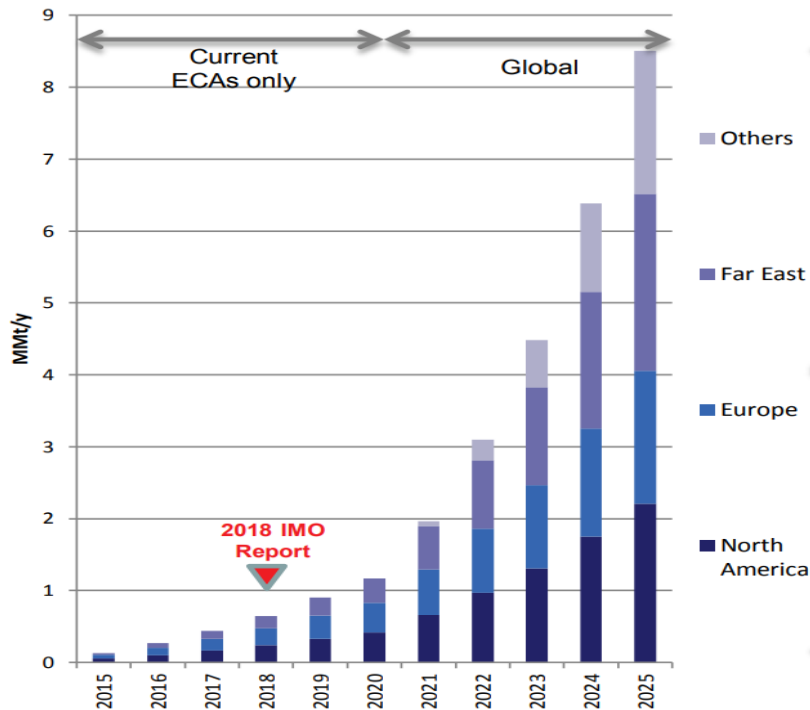

LNG Marine Fuel Consumption by Location

source:: Poten & Partners

Patronat Honorowy | Honorary Patronage



Organizator
Organizer



Współorganizator
Co-organizer



Partner Generalny
General Partner



Partnerzy | Partners



uestco



Partnerzy medialni | Media Partners



Tłumaczenie zapewnia
Bireta

The translation is provided by Bireta





NATURAL GAS AS MARINE FUEL OF THE FUTURE

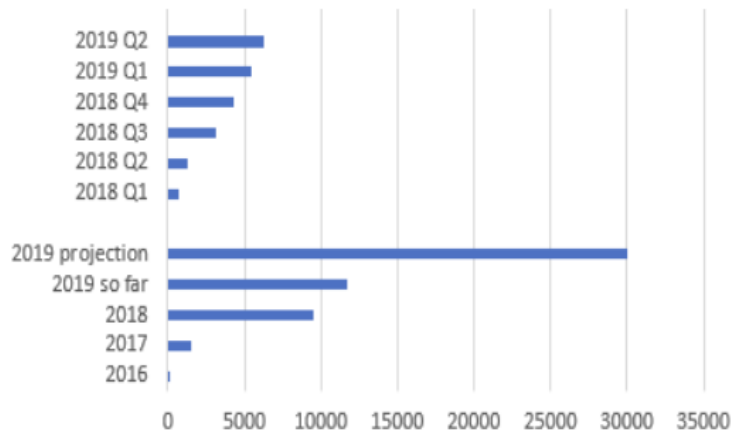

Rotterdam LNG Bunker sales (t)

source: Port of Rotterdam

Patronat Honorowy | Honorary Patronage



Organizator
Organizer



Współorganizator
Co-organizer



Partner Generalny
General Partner



Partnerzy | Partners



Partnerzy Medialni | Media Partners



Tłumaczenie zapewnia
Bireta

The translation is provided by Bireta





LNG BUNKERING - METHODS

Patronat Honorowy | Honorary Patronage



Organizator
Organizer



Współorganizator
Co-organizer



Partner Generalny
General Partner



Partnerzy | Partners



Partnerzy Medialni | Media Partners



Tłumaczenie zapewnia
Bireta

The translation is
provided by Bireta





LNG BUNKERING - METHODS

1. Truck to ship <400m3
2. Replacing LNG (ISO) containers <10x40m3
3. Shore to ship <1,000m3 depends on terminal
4. Ship to ship <18,500m3 for time being....

Patronat Honorowy | Honorary Patronage



Organizator
Organizer



Współorganizator
Co-organizer



Partner Generalny
General Partner



Partnerzy | Partners



Partnerzy Medialni | Media Partners



Tłumaczenie zapewnia
Bireta

The translation is
provided by Bireta





LNG BUNKERING – TRUCK TO SHIP



LNG Bunkering truck to ship in Port of Gdynia

source: Port of Gdynia



LNG Bunkering multiple truck to ship

source: Applied Cryogenics Technologies

Patronat Honorowy | Honorary Patronage



Organizator
Organizer



Współorganizator
Co-organizer



Partner Generalny
General Partner



Partnerzy | Partners



Partnerzy Medialni | Media Partners



Tłumaczenie zapewnia Bireta

The translation is provided by Bireta





LNG BUNKERING – REPLACING LNG CONTAINERS



LNG ISO Container

source: Fuelgarden LNG

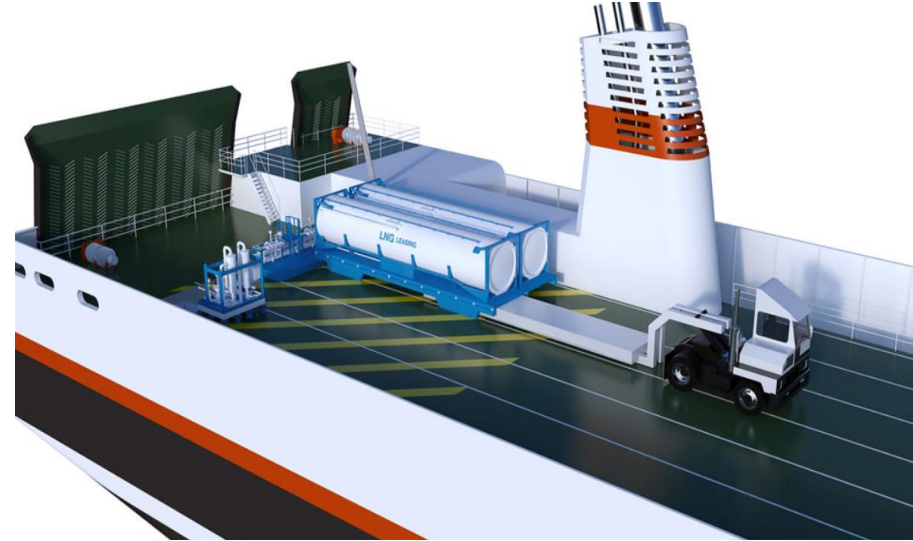

LNG ISO Container on rolltrailer

source: Wartsila

Patronat Honorowy | Honorary Patronage



Organizator
Organizer



Współorganizator
Co-organizer



Partner Generalny
General Partner



Partnerzy | Partners



Partnerzy Medialni | Media Partners



Tłumaczenie zapewnia
Bireta

The translation is
provided by Bireta





LNG BUNKERING – SHORE TO SHIP



Shore to Ship bunkering

source: PitPoint LNG

Patronat Honorowy | Honorary Patronage



Organizator
Organizer



Współorganizator
Co-organizer



Partner Generalny
General Partner



Partnerzy | Partners



Partnerzy Medialni | Media Partners:



Tłumaczenie zapewnia
Bireta

The translation is
provided by Bireta





LNG BUNKERING – SHIP TO SHIP



Ship to Ship bunkering

source: Nauticor (top)/AGA(left)

Ship to Ship bunkering

source: Seatech

Patronat Honorowy | Honorary Patronage



Organizator
Organizer



Współorganizator
Co-organizer



Partner Generalny
General Partner



Partnerzy | Partners



Partnerzy Medialni | Media Partners



Tłumaczenie zapewnia Bireta

The translation is provided by Bireta





LNGBV – CARGO CONTAINMENT SYSTEM

Patronat Honorowy | Honorary Patronage



Organizator
Organizer



Współorganizator
Co-organizer



Partner Generalny
General Partner



Partnerzy | Partners



Partnerzy medialni | Media Partners



Tłumaczenie zapewnia
Bireta

The translation is
provided by Bireta





LNG BUNKERING VESSELS - CONTAINMENT SYSTEM – IMO Type „A”



1. Independent tanks
2. Prismatic shape
3. Max pressure 0.75barg
4. Design temperature -163C
5. Full secondary barrier

IMO Type A LNG Tank

source: LNT Marine

Patronat Honorowy | Honorary Patronage



Organizator
Organizer



Współorganizator
Co-organizer



Partner Generalny
General Partner



Partnerzy | Partners



Partnerzy Medialni | Media Partners



Tłumaczenie zapewnia
Bireta

The translation is
provided by Bireta





LNG BUNKERING VESSELS - CONTAINMENT SYSTEM – IMO Type „B”



1. Independent tanks
2. Prismatic or spherical shape
3. Max pressure 0.75barg
4. Design temperature -163C
5. Partial secondary barrier

IMO Type B LNG Tanks

source: Moss Maritime (left), Exmar (right)

Patronat Honorowy | Honorary Patronage



Organizator
Organizer



Współorganizator
Co-organizer



Partner Generalny
General Partner



Partnerzy | Partners



Partnerzy Medialni | Media Partners



Tłumaczenie zapewnia
Bireta

The translation is
provided by Bireta





LNG BUNKERING VESSELS - CONTAINMENT SYSTEM – IMO membrane Type

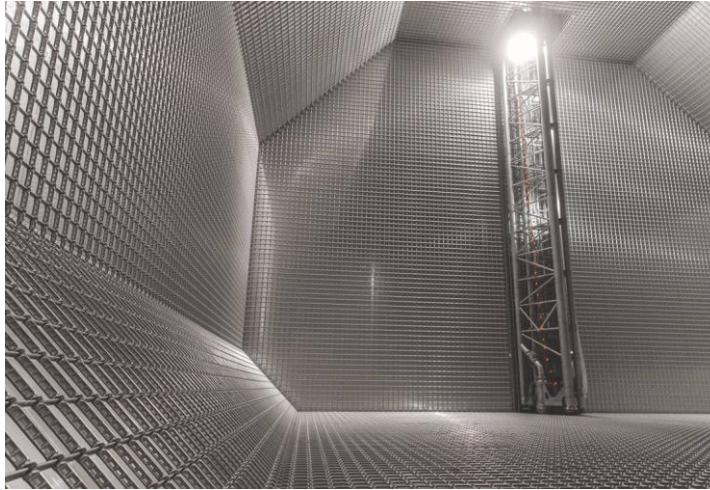

1. Built-in tanks
2. Prismatic shape
3. Max pressure 0.25barg
4. Design temperature -163C
5. Full secondary barrier integrated with hull
6. Patented design and application(GTT)

IMO Membrane LNG Tanks

source: Gaz Transport Technigaz (GTT)

Patronat Honorowy | Honorary Patronage



Organizator
Organizer



Współorganizator
Co-organizer



Partner Generalny
General Partner



Partnerzy | Partners



Partnerzy Medialni | Media Partners



Tłumaczenie zapewnia
Bireta

The translation is
provided by Bireta





LNG BUNKERING VESSELS - CONTAINMENT SYSTEM – IMO Type „C”

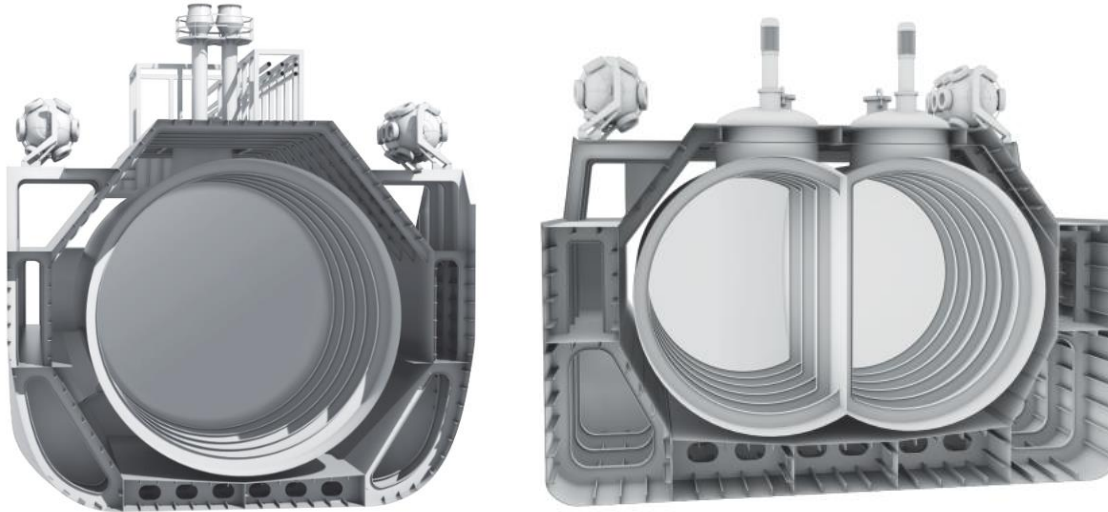

1. Independent tanks
2. Cylindrical shape
3. Max pressure above 2 barg
4. Design temperature -163C
5. No secondary barrier

IMO Type „C” LNG Tanks

source: Seatech (cylindrical - left, bilobe – right)

Patronat Honorowy | Honorary Patronage



Organizator
Organizer



Współorganizator
Co-organizer



Partner Generalny
General Partner



IVECO



uestco



EMERSON



Partnerzy Medialni | Media Partners



Baltic Transport

CNG-LNG.PL

gazeo.pl



Tłumaczenie zapewnia
Bireta

The translation is
provided by Bireta





LNGBV - CARGO HANDLING EQUIPMENT

Patronat Honorowy | Honorary Patronage



Organizator
Organizer



Współorganizator
Co-organizer



Partner Generalny
General Partner



Partnerzy | Partners



Partnerzy Medialni | Media Partners



Tłumaczenie zapewnia
Bireta

The translation is
provided by Bireta





LNG BUNKERING VESSELS – CARGO HANDLING EQUIPMENT (almost the same as for LNGC)



1. LNG manifold
2. LNG pumps
3. Hose handling crane
4. Fenders
5. Fuel gas compressors and vaporizers
6. LNG custody transfer measurement
7. Relieve valves/masts
8. Special LNG bunkering equipment – see next slide

Typical Cargo Handling Equipment for LNGBV

source: Seatech

Patronat Honorowy | Honorary Patronage



Organizator
Organizer



Współorganizator
Co-organizer



Partner Generalny
General Partner



Partnerzy | Partners



Partnerzy Medialni | Media Partners



Tłumaczenie zapewnia
Bireta

The translation is
provided by Bireta





LNG BUNKERING VESSELS – CARGO HANDLING EQUIPMENT



- 6.1. LNG Emergency Release Couplings
- 6.2. LNG loading boom

Emergency Release Couplings and LNG Loading Booms

source: Kanon Loading Equipment

Patronat Honorowy | Honorary Patronage



Organizator
Organizer



Współorganizator
Co-organizer



Partner Generalny
General Partner



Partnerzy | Partners



Partnerzy medialni | Media Partners



Tłumaczenie zapewnia
Bireta

The translation is
provided by Bireta





LNGBV - MANEUVERING

Patronat Honorowy | Honorary Patronage



Organizator
Organizer



Współorganizator
Co-organizer



Partner Generalny
General Partner



Partnerzy | Partners



Partnerzy Medialni | Media Partners



Tłumaczenie zapewnia
Bireta

The translation is
provided by Bireta





LNG BUNKERING SHIPS - MANEUVERING



1. High maneuverability
2. Bow thruster
3. Operation without tug assistance
4. Redundancy
5. No DP needed (but sometime requested)

Typical propulsion arrangement for LNCBV

source: Seatech

Patronat Honorowy | Honorary Patronage



Organizator
Organizer



Współorganizator
Co-organizer



Partner Generalny
General Partner



Partnerzy medialni | Media Partners



Tłumaczenie zapewnia
Bireta

The translation is
provided by Bireta





LNGBV – EXISTING FLEET

Patronat Honorowy | Honorary Patronage



Organizator
Organizer



Współorganizator
Co-organizer



Partner Generalny
General Partner



Partnerzy | Partners



Partnerzy Medialni | Media Partners



Tłumaczenie zapewnia
Bireta

The translation is
provided by Bireta





SEAGAS – WORLD'S FIRST LNG BUNKERING VESSEL - 2015 (170m3)



source: AGA



source: FleetMon

Patronat Honorowy | Honorary Patronage



Organizator
Organizer



Współorganizator
Co-organizer



Partner Generalny
General Partner



Partnerzy | Partners



Partnerzy Medialni | Media Partners



Tłumaczenie zapewnia Bireta

The translation is provided by Bireta





CORAL METHANE – MULTIGAS CARRIER BUILT IN 2007 AT REMONTOWA SHIPBUILDING AND REBUILT TO LNGV IN 2018 (7500m3)



source: Anthony Veder



source: Port of Barcelona/Shell (bottom)

Patronat Honorowy | Honorary Patronage



Organizator
Organizer



Współorganizator
Co-organizer



Partner Generalny
General Partner



Partnerzy | Partners



Partnerzy Medialni | Media Partners



Tłumaczenie zapewnia Bireta

The translation is provided by Bireta





CARDISSA – 2017 (6500m3)



source: Shipspotting

Patronat Honorowy | Honorary Patronage



Organizator
Organizer



Współorganizator
Co-organizer



Partner Generalny
General Partner



Tłumaczenie zapewnia
Bireta

The translation is
provided by Bireta





ENGIE ZEEBRUGGE – 2017 (6500m3)



©Scheepvaartwest

source: Scheepvaartwest

Patronat Honorowy | Honorary Patronage



Organizator
Organizer



Współorganizator
Co-organizer



Partner Generalny
General Partner



Partnerzy medialni | Media Partners



Tłumaczenie zapewnia Bireta

The translation is provided by Bireta





COREALIUS – 2017 (5800m3)



source: Anthony Veder

Patronat Honorowy | Honorary Patronage



Organizator
Organizer



Współorganizator
Co-organizer



Partner Generalny
General Partner



Partnerzy Medialni | Media Partners



Tłumaczenie zapewnia
Bireta

The translation is
provided by Bireta





KAIROS – 2018 (7500m3)



source: Nauticor

Patronat Honorowy | Honorary Patronage



Organizator
Organizer



Współorganizator
Co-organizer



Partner Generalny
General Partner



Partnerzy medialni | Media Partners



Tłumaczenie zapewnia
Bireta

The translation is
provided by Bireta





LNG London – 2019 (3000m3)



source: FleetMon

Patronat Honorowy | Honorary Patronage



Organizator
Organizer



Współorganizator
Co-organizer



Partner Generalny
General Partner



IVECO



uestco



EMERSON



Partnerzy Medialni | Media Partners

Baltic Transport

CNG-LNG.PL

gazeo.pl



Tłumaczenie zapewnia
Bireta

The translation is
provided by Bireta





TITAN LNG – FlexFueller001 – 2019 (3000m3)



source: Titan LNG

Patronat Honorowy | Honorary Patronage



Organizator
Organizer



Współorganizator
Co-organizer



Partner Generalny
General Partner



Tłumaczenie zapewnia
Bireta

The translation is
provided by Bireta





UNDER CONSTRUCTION -2019-2020



source: MES/Stolt LNG



source: FuelNG/Keppel



source: LMG Marine/MOL



source: Keppel/Gazprom



source: Avenir LNG



source: Avenir LNG

Patronat Honorowy | Honorary Patronage



Organizator
Organizer



Współorganizator
Co-organizer



Partner Generalny
General Partner



Partnerzy | Partners



Partnerzy Medialni | Media Partners



Tłumaczenie zapewnia

Bireta
The translation is provided by Bireta





TENDER FOR BUNKERING LNG FUELLED CRUISE VESSELS – 2022 (5000m3)

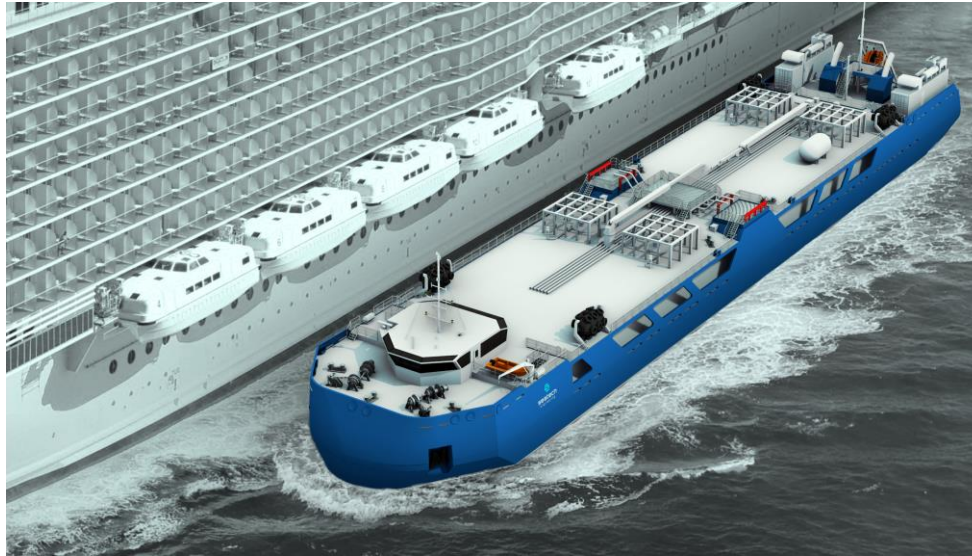

source: Seatech

Patronat Honorowy | Honorary Patronage



Organizator
Organizer



Współorganizator
Co-organizer



Partner Generalny
General Partner



Tłumaczenie zapewnia Bireta

The translation is provided by Bireta





DZIĘKUJĘ/THANK YOU!

Krzysztof Czerski

Energy and Gas Department

e-mail: k.czerski@seatech.com.pl

Mob: +48 697 077 302

Seatech Engineering Sp. z o. o.

80-819 Gdańsk; ul. Okopowa 7

Tel: +48 58 308 15 62

Patronat Honorowy | Honorary Patronage



Organizator
Organizer



Współorganizator
Co-organizer



Partner Generalny
General Partner



Partnerzy | Partners



Partnerzy medialni | Media Partners



Tłumaczenie zapewnia
Bireta

The translation is
provided by Bireta

